

Technical sheet :

# **ES-C 720**

---

 ES-C 720

Technical characteristics			Metric
1.1	Manufacturer		Manitou
1.2	Model Name		ES-C 720
1.3	Power source		Battery
1.4	Operator type		Pedestrian
1.5	Max. capacity	Q	2000 kg
1.6	Load centre of gravity	c	500 mm
1.8	Distance from Load backrest to center of rear axle	x	157 mm
1.9	Wheelbase	y	1470 mm
Weight			
2.1	Service weight		2600 kg
2.2	Weight on front axle (laden) / rear axle (laden)		610 kg / 3985 kg
2.3	Weight on front axle (Unladen) / rear axle (Unladen)		1500 kg / 1100 kg
Wheels			
3.1	Tyres type		Polyurethane
3.5.2	Number of drive wheels / Size of drive wheels		1x254x100
3.3	Number of load wheels / Size of load wheels		2 / 250x100
3.5	Number of front wheels / rear wheels		1 / 2
3.7	Rear wheel gauge	b11	1003 mm
Dimensions			
4.1	Tilt of Mast Forward (deg) / Backward (deg)	$\alpha / \beta$	3 / 8
4.9	Height tiller up min. / max.	h14 / h14	1405 mm / 1005 mm
4.15	Fork height in low position	h13	45 mm
4.19	Overall length	l1	2960 mm
4.20	Length to face of forks	l2	1810 mm
4.21	Overall width	b1	1120 mm
4.22	Forks section / width / length	s / e / l	40 mm / 120 mm / 1150 mm
4.24	Fork carriage width	b3	750 mm
4.31	Ground clearance below mast	m1	31 mm
4.32	Ground clearance at centre of wheelbase	m2	62 mm
4.35	Turning radius	Wa	1826 mm
Performances			
5.1	Travel speed (laden / unladen)		6 km/h / 6 km/h
5.2	Lifting speed (laden / unladen)		0.11 m/s / 0.20 m/s
5.3	Lowering speed (laden / unladen)		0.22 m/s / 0.21 m/s
5.10	Service brake		Electro magnetic
Engine			
6.1	Drive motor rating S2 60 min		2 kW
6.2	Lift motor rating at S3 15%		4 kW
6.3	Battery according to DIN 43531/35/36 A, B, C		DIN 43535-B
6.4	Battery / Batteries capacity		24 V / 315 Ah
6.5	Battery weight (+/- 5%)		275 kg
Miscellaneous			
8.1	Type of drive control		DC
8.4	Sound level at the driver's ear according to DIN 12 053		65 dB(A)

## ES-C 720 - Dimensional drawing

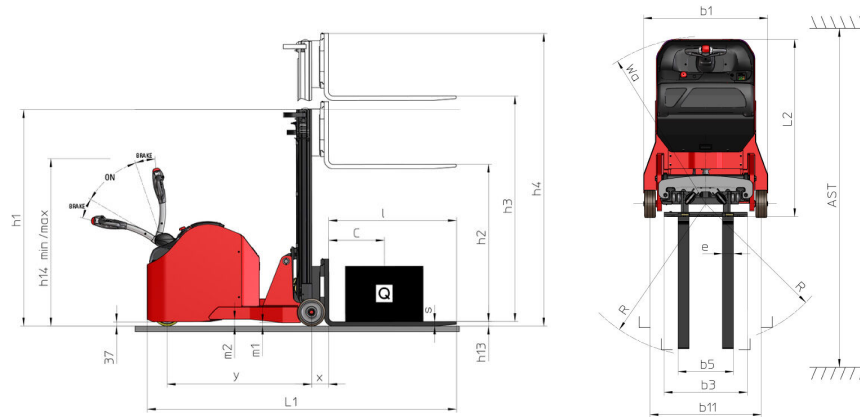

## Characteristics of masts and residual capacities

Central Cylinder Simplex		CCS 15	CCS 17
h3 - Mast lifting height *	mm	2840000	2840000
h2 - Mast free lift *	mm	1420	1420
h1 - Mast height lowered	mm	1955	1955
h4 - Mast height extended	mm	3455000	3455000
$\beta$ - Mast inclination (rear)	°		3
Residual capacity without attachment (Industrial load chart)	kg	2000	2000

Full Visibility Duplex		FVD 29	FVD 34	FVD 38
h3 - Mast lifting height *	mm	2840000	2840000	2840000
h2 - Mast free lift *	mm	1420	1420	1420
h1 - Mast height lowered	mm	1955	1955	1955
h4 - Mast height extended	mm	3455000	3455000	3455000
Residual capacity without attachment (Industrial load chart)	kg	2000	2000	1600

Free Lift Duplex		FLD 29	FLD 34
h3 - Mast lifting height *	mm	2840000	2840000
h2 - Mast free lift *	mm	1420	1420
h1 - Mast height lowered	mm	1955	1955
h4 - Mast height extended	mm	3455000	3455000
Residual capacity without attachment (Industrial load chart)	kg	2000	2000

Free Lift Triplex		FLT 42	FLT 47	FLT 54
h3 - Mast lifting height *	mm	2840000	2840000	2840000
h2 - Mast free lift *	mm	1420	1420	1420
h1 - Mast height lowered	mm	1955	1955	1955
h4 - Mast height extended	mm	3455000	3455000	3455000
$\beta$ - Mast inclination (rear)	°	3	3	
Residual capacity without attachment (Industrial load chart)	kg	1300	1050	850



Siège Social

430 rue de l'Aubinière - 44150 Ancenis Cedex - France

Tel: +33(0)2 40 09 10 11 - Fax: +33 (0)2 40 09 10 97

[www.manitou.com](http://www.manitou.com)



This brochure describes versions and configuration options for Manitou products which may be fitted with different equipment. The equipment described in this brochure may be standard, optional or not available depending on version. Manitou reserves the right to change the specifications shown and described at any time and without prior warning. The manufacturer is not liable for the specifications given. For more information, contact your Manitou dealer. Non-contractual document. Product descriptions may differ from actual products. List of specifications is not comprehensive. The logos and visual identity of the company are the property of Manitou and may not be used without authorisation. All rights reserved. The photos and diagrams contained in this brochure are provided for information only.

MANITOU BF SA - Limited company with board of directors - Share capital: 39,668,399 euros - 857 802 508 RCS Nantes