

Technical sheet :

ES 504 GPF - ES-C 504



Technical characteristics			Metric
1.1	Manufacturer		Manitou
1.2	Model Name		ES 504 GPF
1.3	Power source		Battery
1.4	Operator type		Pedestrian
1.5	Max. capacity	Q	400 kg
1.6	Load centre of gravity	c	400 mm
1.8	Distance from Load backrest to center of rear axle	x	96 mm
1.9	Wheelbase	y	817 mm
Weight			
2.1	Service weight		1120 kg
Wheels			
3.1	Tyres type		Polyurethane
3.5.2	Number of drive wheels / Size of drive wheels		1x230x70
3.3	Number of load wheels / Size of load wheels		2 / 150x70
3.5	Number of front wheels / rear wheels		1 / 2
3.7	Rear wheel gauge	b11	826 mm
Dimensions			
4.9	Height tiller up min. / max.	h14 / h14	830 mm / 1385 mm
4.15	Fork height in low position	h13	35 mm
4.19	Overall length	l1	1898 mm
4.20	Length to face of forks	l2	1098 mm
4.21	Overall width	b1	923 mm
4.22	Forks section / width / length	s / e / l	30 mm / 60 mm / 800 mm
4.24	Fork carriage width	b3	750 mm
4.31	Ground clearance below mast	m1	60 mm
4.32	Ground clearance at centre of wheelbase	m2	69 mm
4.35	Turning radius	Wa	1220 mm
Performances			
5.1	Travel speed (laden / unladen)		4.50 km/h / 4.50 km/h
5.2	Lifting speed (laden / unladen)		0.30 m/s / 0.18 m/s
5.3	Lowering speed (laden / unladen)		0.22 m/s / 0.27 m/s
5.10	Service brake		Electro magnetic
Engine			
6.1	Drive motor rating S2 60 min		1.50 kW
6.2	Lift motor rating at S3 15%		3 kW
6.3	Battery according to DIN 43531/35/36 A, B, C		DIN 43535-B
6.4	Battery / Batteries capacity		24 V / 180 Ah
6.5	Battery weight (+/- 5%)		189 kg
Miscellaneous			
8.1	Type of drive control		AC
8.4	Sound level at the driver's ear according to DIN 12 053		65 dB(A)

ES 504 GPF - ES-C 504 - Dimensional drawing

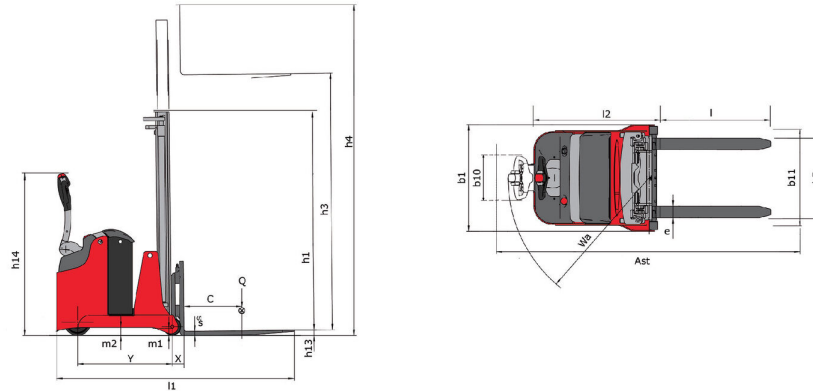

Characteristics of masts and residual capacities

Central Cylinder Simplex		CCS 15	CCS 17
h3 - Mast lifting height *	mm	2850	2850
h1 - Mast height lowered	mm	1931	1931
h4 - Mast height extended	mm	3500	3500
Residual capacity without attachment (Industrial load chart)	kg	400	400

Full Visibility Duplex		FVD 29	FVD 34	FVD 38
h3 - Mast lifting height *	mm	2850	2850	2850
h1 - Mast height lowered	mm	1931	1931	1931
h4 - Mast height extended	mm	3500	3500	3500
Residual capacity without attachment (Industrial load chart)	kg	400	400	300

Free Lift Duplex		FLD 29	FLD 34
h3 - Mast lifting height *	mm	2850	2850
h1 - Mast height lowered	mm	1931	1931
h4 - Mast height extended	mm	3500	3500
Residual capacity without attachment (Industrial load chart)	kg	400	400

Free Lift Triplex		FLT 42
h3 - Mast lifting height *	mm	2850
h1 - Mast height lowered	mm	1931
h4 - Mast height extended	mm	3500
Residual capacity without attachment (Industrial load chart)	kg	200

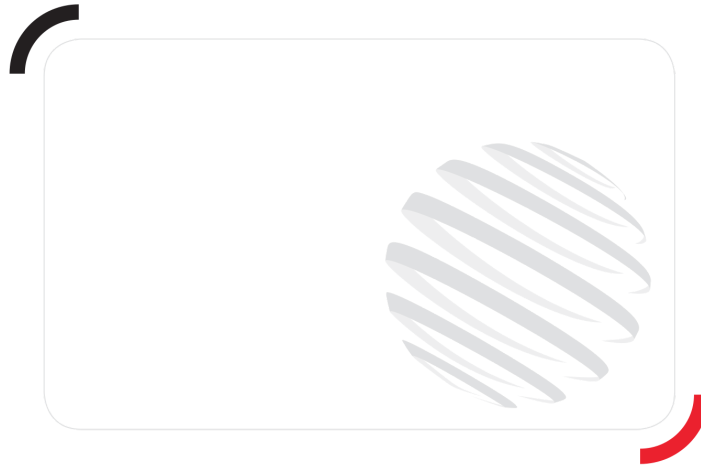

Siège Social

430 rue de l'Aubinière - 44150 Ancenis Cedex - France

Tel: +33(0)2 40 09 10 11 - Fax: +33 (0)2 40 09 10 97

www.manitou.com



This brochure describes versions and configuration options for Manitou products which may be fitted with different equipment. The equipment described in this brochure may be standard, optional or not available depending on version. Manitou reserves the right to change the specifications shown and described at any time and without prior warning. The manufacturer is not liable for the specifications given. For more information, contact your Manitou dealer. Non-contractual document. Product descriptions may differ from actual products. List of specifications is not comprehensive. The logos and visual identity of the company are the property of Manitou and may not be used without authorisation. All rights reserved. The photos and diagrams contained in this brochure are provided for information only.

MANITOU BF SA - Limited company with board of directors - Share capital: 39,668,399 euros - 857 802 508 RCS Nantes