

Technical sheet :

ES 412 LE



	Technical characteristics		Metric
1.1	Manufacturer		Manitou
1.2	Model Name		ES 412 LE
1.3	Power source		Battery
1.4	Operator type		Pedestrian
1.5	Max. capacity	Q	1200 kg
1.6	Load centre of gravity	c	600 mm
1.8	Distance from Load backrest to center of rear axle	x	683 m
1.9	Wheelbase	y	1245 mm
	Weight		
2.1	Service weight		924 kg
2.2	Weight on front axle (laden) / rear axle (laden)		743 kg / 1381 kg
2.3	Weight on front axle (Unladen) / rear axle (Unladen)		612 kg / 262 kg
	Wheels		
3.1	Tyres type		Polyurethane
3.5.2	Number of drive wheels / Size of drive wheels		1x230x75
3.3	Number of load wheels / Size of load wheels		2 / 82x70
3.4	Number of castor wheels / Dimensions of castor wheels		1 / 1
3.4	Number of stabilizer wheels / Size of the stabilizer wheels		2 / 125x50
3.5	Number of front wheels / rear wheels		2 / 2
3.6	Front wheel gauge	b10	517 mm
3.7	Rear wheel gauge	b11	978 mm
	Dimensions		
4.2	Height mast lowered *	h1	1940 mm
4.4	Lifting Height	h3	2940 mm
4.5	Height mast extended *	h4	3365 mm
4.9	Height tiller up max.	h14	1050 mm
4.15	Fork height in low position	h13	85 mm
4.19	Overall length	l1	1870 mm
4.20	Length to face of forks	l2	720 mm
4.21	Overall width	b1	1106 mm
4.22	Forks section / width / length	s / e / l	60 mm / 180 mm / 1150 mm
4.24	Fork carriage width	b3	680 mm
4.31	Ground clearance below mast	m1	35 mm
4.32	Ground clearance at centre of wheelbase	m2	20 m
	Performances		
5.1	Travel speed (laden / unladen)		6 km/h / 6 km/h
5.2	Lifting speed (laden / unladen)		0.12 m/s / 0.24 m/s
5.3	Lowering speed (laden / unladen)		0.30 m/s / 0.20 m/s
5.8	Max Gradeability (laden / unladen)		8 % / 10 %
5.10	Service brake		Electro magnetic
	Engine		
6.1	Drive motor rating S2 60 min		1.20 kW
6.2	Lift motor rating at S3 15%		3 kW
6.3	Battery according to DIN 43531/35/36 A, B, C		DIN 43535-B
6.4	Battery / Batteries capacity		24 V / 180 Ah
6.5	Battery weight (+/- 5%)		176 kg
	Miscellaneous		
8.1	Type of drive control		AC
8.4	Sound level at the driver's ear according to DIN 12 053		65 dB(A)

ES 412 LE - Dimensional drawing

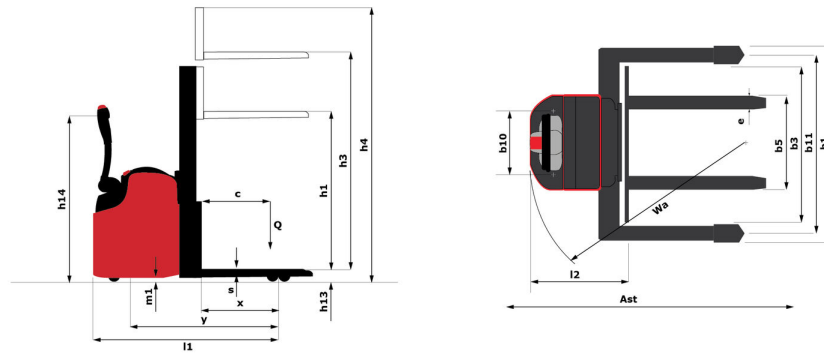

Characteristics of masts and residual capacities

Full Visibility Duplex		FVD 29	FVD 34	FVD 38
h3 - Mast lifting height *	mm	2940	3440	3840
h1 - Mast height lowered	mm	1940	2190	2390
h4 - Mast height extended	mm	3365	3865	4265
Residual capacity at max height	kg	1200	1200	1200

Free Lift Duplex		FLD 29	FLD 34
h3 - Mast lifting height *	mm	2935	3435
h2 - Mast free lift *	mm	1510	1760
h1 - Mast height lowered	mm	1940	2190
h4 - Mast height extended	mm	3365	3865
Residual capacity at max height	kg	1200	1200
Height at max capacity	mm	2935	3435

Free Lift Triplex		FLT 42
h3 - Mast lifting height *	mm	4240
h2 - Mast free lift *	mm	1470
h1 - Mast height lowered	mm	1960
h4 - Mast height extended	mm	4730
Residual capacity at max height	kg	1200
Height at max capacity	mm	4240

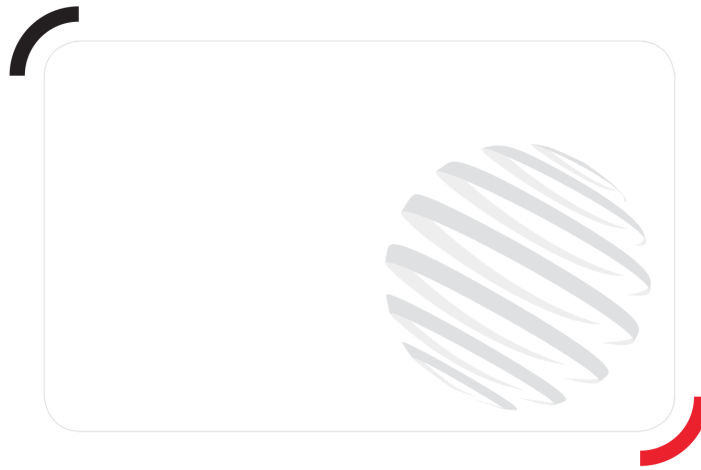

Siège Social

430 rue de l'Aubinière - 44150 Ancenis Cedex - France

Tel: +33(0)2 40 09 10 11 - Fax: +33 (0)2 40 09 10 97

www.manitou.com



This brochure describes versions and configuration options for Manitou products which may be fitted with different equipment. The equipment described in this brochure may be standard, optional or not available depending on version. Manitou reserves the right to change the specifications shown and described at any time and without prior warning. The manufacturer is not liable for the specifications given. For more information, contact your Manitou dealer. Non-contractual document. Product descriptions may differ from actual products. List of specifications is not comprehensive. The logos and visual identity of the company are the property of Manitou and may not be used without authorisation. All rights reserved. The photos and diagrams contained in this brochure are provided for information only.

MANITOU BF SA - Limited company with board of directors - Share capital: 39,668,399 euros - 857 802 508 RCS Nantes